

Operating Instructions
Medium capacity
Glassware Washer
G 7825 / G 7826

To prevent accidents
and machine damage
read these instructions

before
installation or use.



IMPORTANT SAFETY INSTRUCTIONS	5
Description of the machine	9
Guide to the machine	10
Opening and closing the door	15
Automatic mobile unit recognition (AWK)	16
Mobile unit coding	16
Setting mobile unit coding	17
Applications	19
Laboratory glassware (LG)	21
Transfer cart for loading and unloading the machine	22
Adding of liquid detergents and neutralizers	24
Priming the DOS dispensers	24
Filling the containers with the relevant detergent or neutralizer	25
Priming the liquid dispensing systems	26
Dispensing system maintenance	26
External Dispensing systems	26
Operation	27
Power switch	27
Turning on	27
To change the operating level	27
Starting a program	28
Program sequence	29
Turning off	29
To change or cancel a program	30
Cancelling a program	31
Serial interface	32
Cleaning and Care	33
Cleaning the filters in the wash cabinet	33
Cleaning the fine filter	33
Cleaning the flat filter	33
Cleaning the filter system for the circulation pump	33
Drying unit (TA) - Cleaning and care	34
Changing the coarse filter	34
Changing the fine filter	34
Maintenance of report printer (Option)	35
Replacing the print paper	35
Replacing the ribbon cartridge	35

Contents

Installation	36
Steam/Electro or Electro/Steam conversion	36
Electrical connection	37
Plumbing	38
Water connection	38
Do not shorten hoses!	38
Requirements (refer to the Installation Diagram for more information).	38
Drainage	39
Technical Data	40
After sales service	41
Caring for the environment	42

IMPORTANT SAFETY INSTRUCTIONS

This machine conforms to current safety requirements. Inappropriate use can however lead to personal injury and property damage. Read the operating instructions carefully before starting to use this machine. Keep these instructions in a safe place, and make them available to future users.

Use

■ This machine is designed for commercial use and for specialized applications only, as described in these Operating Instructions. Do not use for purposes other than those for which it was designed, as this might be dangerous. Miele is not responsible for damages caused by improper use.

■ The installation of this unit in non stationary locations (e.g. ships) must be performed by a qualified installer or service agency in strict accordance with national and local safety regulations and standards.

Please pay attention to the following notes, to maintain safe procedures.

■ The machine should be commissioned and then maintained only by a Miele Service Technician. Repairs by unqualified persons could be dangerous.

■ Do not install the machine in an area where a danger of explosion or of freezing may be present.

■ Be certain this appliance is properly installed and grounded by an authorized technician. To guarantee the electrical safety of this appliance, continuity must exist between the appliance and an effective grounding system. It is imperative that this basic safety requirement be met. If there is any doubt, have the electrical system checked by a qualified technician. The manufacturer cannot be held responsible for damage or injury caused by the lack of or inadequacy of an effective grounding system (e.g. electric shock).

■ A damaged machine is dangerous. Turn off the machine immediately at the power switch and call the Miele Service Department.

■ Personnel operating the machine should be trained regularly. Children and untrained personnel must not be allowed access to the machine or its controls.

IMPORTANT SAFETY INSTRUCTIONS

Take care when handling liquids such as detergents, neutralizing agents, wetting agents and rinse aids. These may contain irritant or corrosive ingredients, acids or alkalis. Never use any organic solvent, as the danger of an explosion exists. Wear protective gloves and goggles. The manufacturer's safety conditions must be observed at all times.

The water in the machine must not be used as drinking water.

Be careful when sorting items with sharp pointed ends. Position them in the machine that you do not hurt yourself or create danger for other operators.

When using this machine regard the high temperatures and be especially careful not to scald or burn yourself. When opening the door bypassing the electrical lock, a danger of burning, scalding or corrosion exists. Let mobile units, inserts and cleaned items cool before touching them. Any water which may remain in containers will be very hot and must be emptied into the wash cabinet.

After drying with the TA drying unit open the door to allow the items and inserts to cool.

Do not touch the heating elements (under the wide area filter) during or directly after the end of a program, you could burn yourself. They remain hot for some time after the end of the program.

If the boiler has been programmed to "BOILER READY", be particularly careful of hot water and steam when opening the door. Danger of burning or scalding. The water inlet pipe to the wash cabinet is located, as viewed from the unclean side, underneath the basket runner on the left hand side.

Steam heating is permissible up to a pressure of 145 psi. This corresponds to a water steam temperature of 179 °C.

Never clean the machine near or with a water or high pressure hose.

Before servicing, disconnect the power supply by either removing the fuse, unplugging the unit or manually "tripping" the circuit breaker.



Mount on non-combustible floor only!

IMPORTANT SAFETY INSTRUCTIONS

The following points should be observed to assist in maintaining quality standards, for critical lab glassware, to protect patients, and to avoid damage to the loads being cleaned.

■ Use only Miele approved cleaning agents with this machine. Use of unsuitable cleaning agents could adversely affect the components of the machine. Damages resulting from using unsuitable cleaning agents are not covered by the warranty.

■ Pre-treating (e.g. with cleaning agents), certain soiling and cleaning agents with a chemical interaction, can cause foam. For pre-treatment and / or cleaning only use low-sudsing detergents which have been approved by Miele. Suds can have an adverse effect on the operation of the machine.

■ When a chemical additive is recommended, the manufacturer of the machine takes no responsibility for the effect of the chemical on the items being cleaned.

■ The machine must only be operated with water and the recommended cleaning agents. Organic solvents must not be used in the machine, as there is the danger under certain circumstances of explosion and damage to rubber and synthetic materials.

■ In critical applications where very high requirements have to be met, it is strongly recommended that all the relevant factors for the process, such as cleaning agent, quality of water etc. are discussed with the Miele Applications Specialists.

■ If the cleaning result is subject to these particularly stringent requirements (e.g. chemical analysis, specialized processes), a regular quality control test should be carried out by the user to ensure that required standards of cleanliness are being achieved.

IMPORTANT SAFETY INSTRUCTIONS

■ The mobile units and special inserts should only be used for their specific application.

■ Empty any containers or utensils before arranging them in the machine.

■ Do not allow any remains of acids or solvents, and in particular hydrochloric acid or chloride solutions to get into the wash cabinet as well as corroding ferrous material. Similarly avoid any materials with a corrosive effect. The presence in compounds of any solvents should be minimal, (especially those in hazard class A1).

■ Ensure that solutions or steam containing hydrochloric acid do not come into contact with the stainless steel casing of the machine, to avoid any corrosion damage.

■ Please follow the installation advice in these instructions and the separate Installation Instructions.

Using accessories

■ Only specific additional equipment made by Miele should be connected to this machine. Consult the Miele Application Specialist on the type and application of such equipment.

■ Only Miele mobile units, modules and inserts should be used. If equipment from another manufacturer is used, Miele cannot ensure the cleaning and disinfection results. Damage or injury caused by this are excluded from the warranty.

Disposal of an old appliance

■ When discarding a lab washer, disconnect it from the power supply, and cut off the power cord. The old appliance may be contaminated by blood or other body fluids and must be disinfected before disposal.

For environmental and safety reasons ensure the machine is completely drained of any residue water and cleaning agent. (Observe safety regulations and wear safety goggles and gloves). Make the door lock inoperative or remove the door completely, so that children cannot accidentally shut themselves in. Make appropriate arrangements for the safe disposal of the machine.

Machines with tank system, remove the water from the tank before disposing the machine.

The manufacturer cannot be held responsible for any damage caused by non-observance of these Warning and Safety instructions.

Description of the machine

The Miele G 7825 / G 7826 Glassware Washing System is designed to provide high-throughput glassware cleaning in areas where space is at a premium. This unit is ideal for cleaning both large volumes of small items and difficult to clean large items.

This high tech system has been proven in hundreds of laboratories worldwide. It features the user-friendly Profitronic programming system for easy programming, a fully modular basket system for washload flexibility and an automatic basket recognition system to help eliminate user error.

Options

- Drying unit (TA)
- Steam condenser (DK)
- Report printer (PRT)
- Dispensing systems DOS 2 and DOS 4

Guide to the machine

Electronic controls

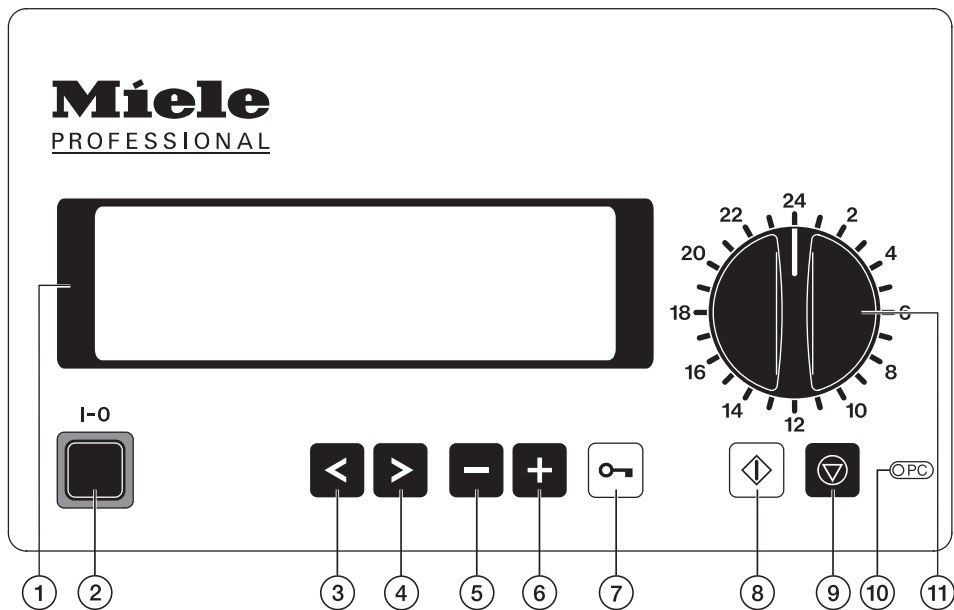

- ① **Display**
with screen saver, background light switches off automatically after 15 minutes, hit any key to turn the background light on again.
- ② **On/Off button (I-0)**
- ③ **Cursor left**
moves the cursor to the left:
 - to the previous menu
 - to the previous parameter
 - to the previous input location
- ④ **Cursor right**
moves the cursor to the right:
 - to the next menu
 - to the next parameter
 - to the next input location
- ⑤ **Minus button**
 - program selection for programs over 24
 - going back pagewise in menus
 - type in figures and letters
 - change default settings, e.g. service parameter
- ⑥ **Plus button**
 - program selection for programs over 24
 - going forward pagewise in menus
 - type in figures and letters
 - change default settings, e.g. service parameter
- ⑦ **Door switch**
- ⑧ **Start button**
 - Starting a program
 - Activating insert mode
 - Confirming settings
 - Confirming menu points, to get to the respective submenu
- ⑨ **Stop button**
 - Canceling a program
 - Leaving the insert window without confirming
 - Leaving a menu
- ⑩ **Optical interface**
(for service technician)
- ⑪ **Program selector**
Selecting programs 1-23

Guide to the machine

Unclean side

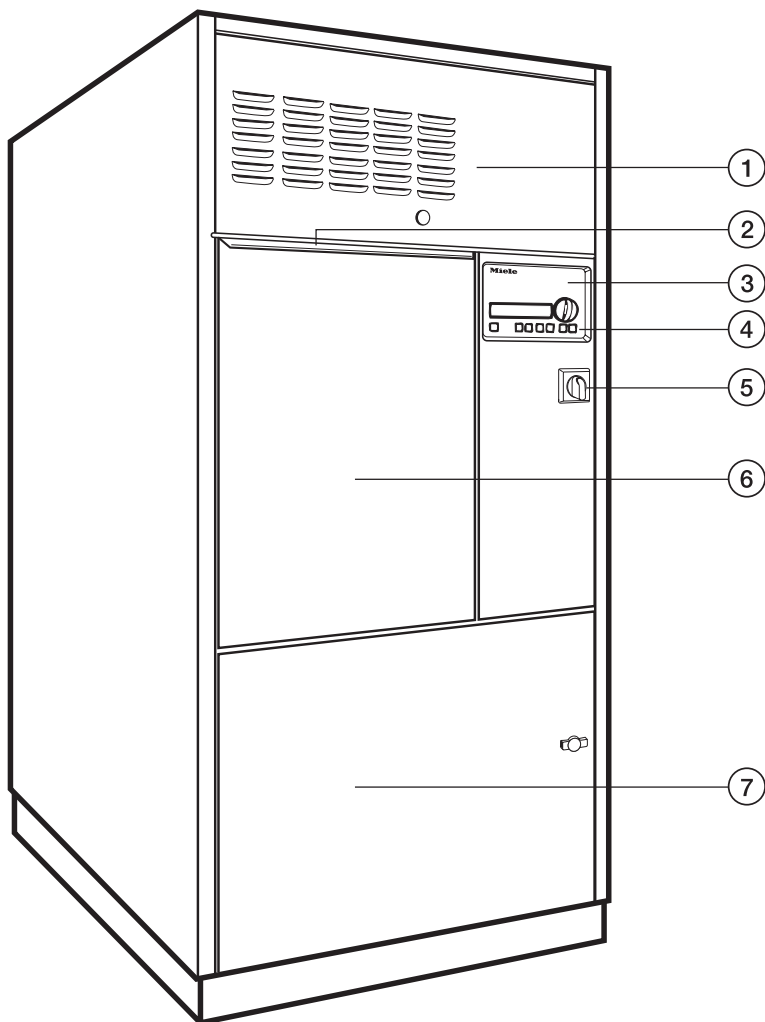

① Drying unit (TA) (optional)

② Handle

③ Electronic control "Profitronic"
(see "Programming manual")

④ Controls

⑤ Power switch (with "Emergency
cut-off" function for Service)

⑥ Drop-down door (closed)

⑦ Service panel

Unclean side

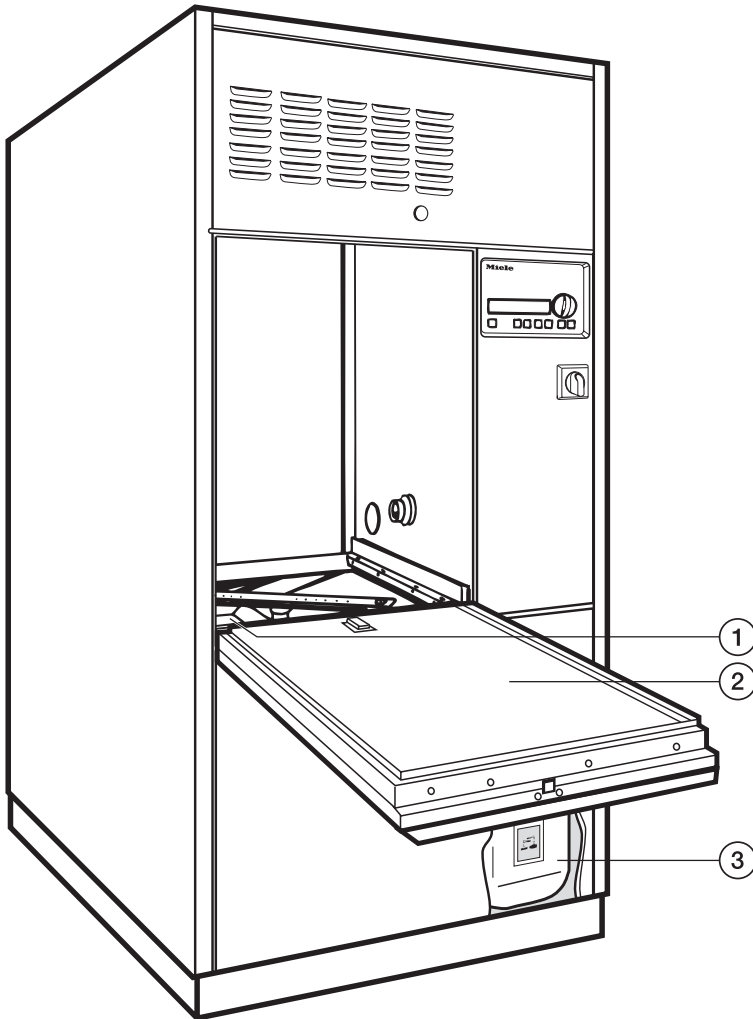

- ① Filter combination
- ② Drop-down door (open)
- ③ Containers for dispensing systems
DOS 1 / DOS 3
(optional DOS 2 / DOS 4)

Guide to the machine

Clean side (G 7826 only)

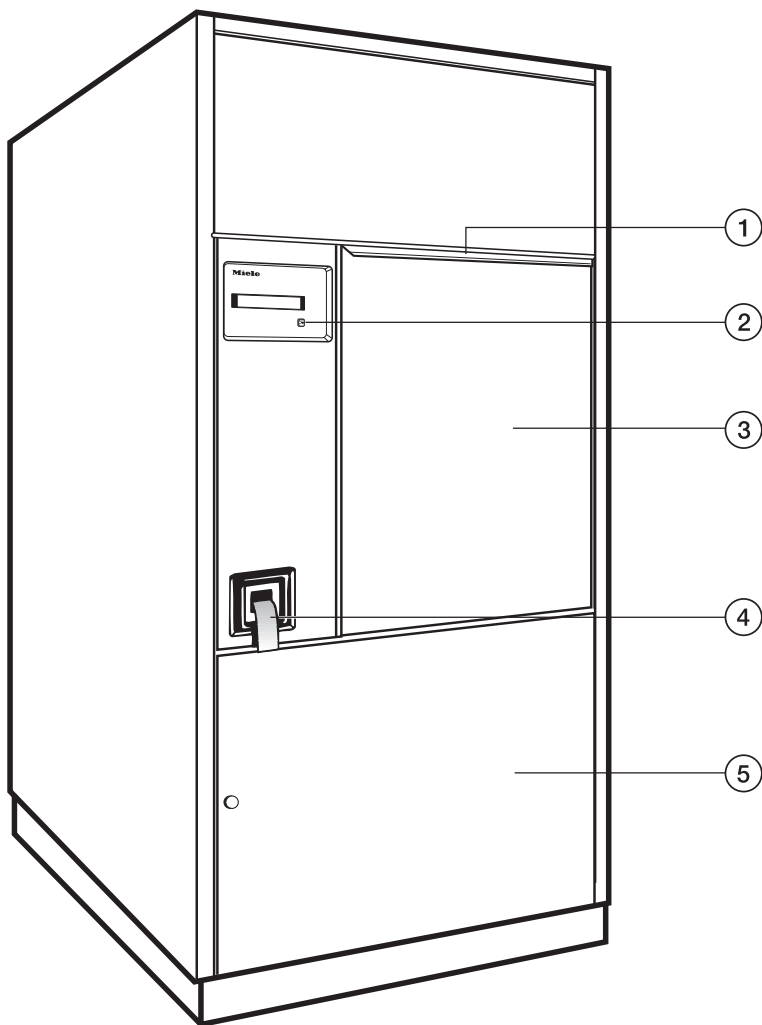

① Handle

② "Door" button

③ Drop-down door (closed)

④ Printer (optional)

G 7825 on the unclean side

⑤ Service panel

Opening and closing the door

The door can only be opened when:

- the lab glassware washer is connected to the electrical supply,
- the red (“emergency cut-off”) power switch is in the **I-ON** position,
- the **I-0** On-Off button is pressed in, and
- no program is running.

The door on the **clean side** (G 7826) can only be opened when:

- DESIN (disinfection) programs have been correctly completed.

or

- the “Door locking” function is active (see “Machine function - Door locking” in the “Programming Manual”).

Opening the door

- Press the  door button, hold the door handle and open the door.

 Do not touch the heating elements (under the wide area filter) during or directly after the end of a program, you could burn yourself. If the boiler has been programmed to “BOILER READY”, be particularly careful of hot water and steam when opening the door. Danger of burning or scalding. The water inlet pipe to the wash cabinet is located, as viewed from the unclean side, underneath the basket runner on the left hand side.

To close the door

- Lift the door upwards and push until it clicks shut.

Automatic mobile unit recognition (AWK)

In operating level C the AWK (optional) attributes a fixed program place to a mobile unit with valid coding. Program places 1-15 are reserved for the AWK automatic mobile unit recognition.

The unit coding (on the mobile unit) and the program place with the corresponding program (in the "Profitronic" electronic control unit) must match.

- Each mobile unit must be coded before being used for the first time. See "Mobile unit coding".
- The wash program through which the mobile unit is coded has to be assigned to the relevant program place (operating level D, see the "System function - Selector switch organization" section in the Programming Manual).

Important!

Before starting the program with the "Start" button , check if the program needed for this mobile unit is displayed. Insufficient wash results may occur! Always check that programs for mobile units with AWK (on fixed program places) are not exchanged.

Mobile unit coding

The automatic mobile unit recognition feature assigns a program place to a mobile unit. The mobile units must be coded with a magnetic strip, via a bit combination. In operating level C the only program available for a coded mobile unit is the one assigned to the corresponding program place.

When a coded mobile unit is inserted in the machine and the door closes, the automatic mobile unit recognition selects the assigned program. Be sure no small items connect to the magnetic strip.

Press  to start the program.

Coding is made up of 5 bits:

- Bits 1 to 4 define the mobile unit code,
- Bit 5 serves as a control (Parity-Bit).

Bit 6 controls the volume of water intake and the circulation pump for mobile units with side coupling. This setting cannot be changed!

Mobile units without side coupling are coded with tracks which do not contain Bit 6!

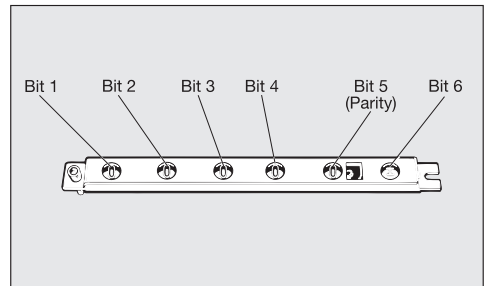

Automatic mobile unit recognition (AWK)

Mobile unit coding strip

15 different codes can be set. They are assigned to program places 1 to 15.

Under "System function - Selector switch organization" the matching programs have to be put into the first 15 program places.

Prog.-place	Bit 1	Bit 2	Bit 3	Bit 4	Bit 5 Parity-Bit
-	0	0	0	0	0
1	1	0	0	0	1
2	0	1	0	0	1
3	1	1	0	0	0
4	0	0	1	0	1
5	1	0	1	0	0
6	0	1	1	0	0
7	1	1	1	0	1
8	0	0	0	1	1
9	1	0	0	1	0
10	0	1	0	1	0
11	1	1	0	1	1
12	0	0	1	1	0
13	1	0	1	1	1
14	0	1	1	1	1
15	1	1	1	1	0

The coded total must be an even number. Setting Bit 6 is not included in this calculation.

If the coded total gives an odd number the message CHECK MOBILE UNIT RECOGNITION appears. If the mobile unit code equals 0, the message NO MOBILE UNIT RECOGNITION appears. In both cases the program cannot be started. The mobile unit recognition must be re-set.

Setting mobile unit coding

To set or alter the coding of a mobile unit with automatic recognition (AWK) proceed as follows:

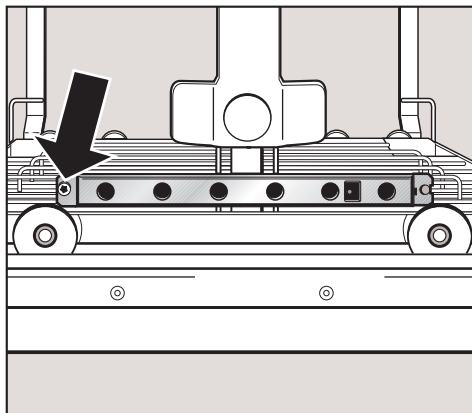

- Unscrew the track with an AWK (allen wrench) and remove it from the retainer.

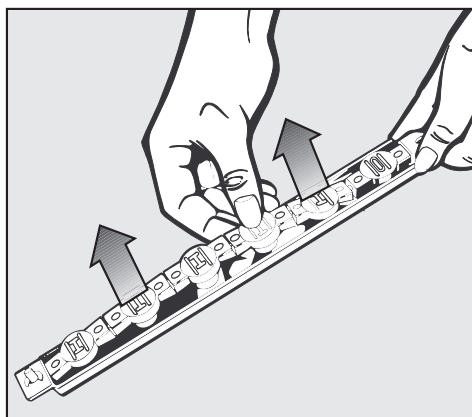

- Remove the magnetic strip from the track.

Automatic mobile unit recognition (AWK)

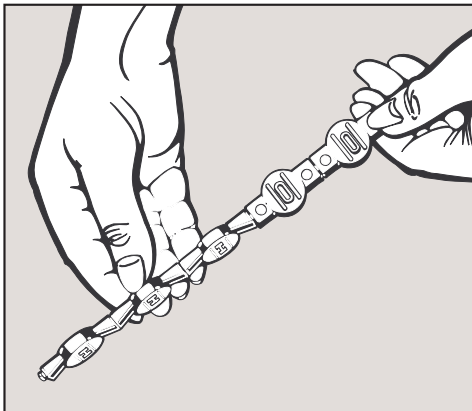

- Set the program place coding.

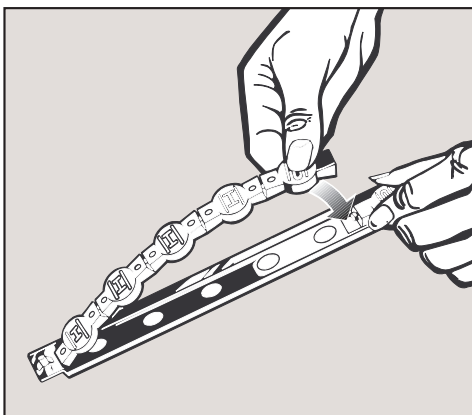

- Put the magnetic strip back in the track.

Important:

The magnetic strip must be placed in the track so that the Bit coding, set according to the chart, is visible through the round windows of the track.

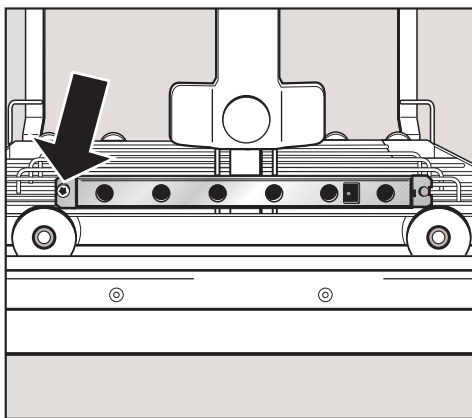
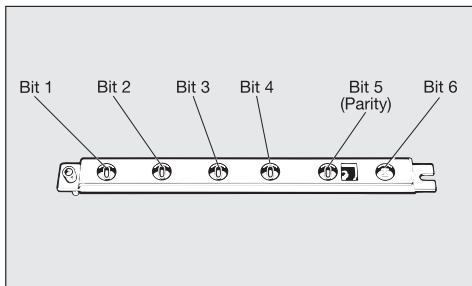

- Place the track in the holder of the mobile unit and screw firmly in place.

Bit 6 is not an integral part of the modifiable magnetic strip. Make sure that you code mobile units with side coupling to a track where Bit 6 is set to 1. Mobile units without side coupling must be coded with a track that does not have Bit 6.

The magnetic strips on the G 7825 / G 7826 must have **gray** magnets. The magnetic strips on the G 7827 / G 7828 must have **black** magnets.

The machine can be fitted with a variety of mobile units, baskets and inserts, depending on the cleaning application in question.

The diversity of these units and inserts is so great that it is not possible to illustrate them all or give detailed instructions of their use here. For example, there are inserts for direct spraying or rinsing which contain internal surfaces, tubes and pipes that need stringent cleaning.

Loading the machine

Removing excess soils

- Empty all containers before loading them into the machine (paying particular attention to regulations regarding infectious diseases).

 Ensure that no acid or solvent residues, especially hydrochloric acid or chlorides get into the wash cabinet.

Preparing items for cleaning

Notes

- Are the items to clean correctly sorted, loaded and connected?
- Are the spray arms clean and can they rotate freely?
- Is the filter combination free of coarse soiling? Clean if necessary.
- Is the adapter to the water inlet in place? The spray arms correctly connected?
- Are the detergent and neutralizer containers full?

Applications

Note

- Load the items to be washed so that water can access all surfaces. This ensures that they will be properly cleaned.
- Do not place items to be cleaned inside other pieces where they may be concealed.
- Hollow vessels such as beakers, measuring cylinders, flasks, etc. should be inverted and placed in the correct inserts so that water can flow in and out unrestricted. A cover net can be used to reduce the risk of movement during the wash process.
- Use a cover net (e.g. an A 2) or mesh tray to secure small and/or lightweight items to prevent them from blocking the spray arms or being caught in the magnetic strip on the automatic mobile unit recognition system.
- Deep based items should be placed at an angle to allow water run off easily.
- Tall, narrow pieces should be placed in the center of the baskets. This ensures good coverage of water.
- Mobile units with an adapter must engage correctly.
- Engage inserts correctly into the module carts.
- The spray arms must not be blocked by tall items or items which hang down in their path. If necessary, manually rotate the arms to test.

Select mobile units, baskets and inserts appropriate for the application.

Laboratory glassware (LG)

Wide-necked glassware, such as wide necked erlenmeyer flasks and petri dishes, or glassware with a cylindrical form, e.g. test tubes, can be cleaned inside and outside by a rotating spray arm. General glassware, such as beakers, conical flasks, petri dishes, test tubes etc. can be arranged in full size, half or quarter inserts at the higher or lower level.

Mobile injector units are available for direct injection spraying of narrow necked flasks, pipettes, etc.

The following instructions relate only to basic preparation and loading of glassware.

Loading the machine

Removing excess soils

- Empty all glassware before loading into the machine.

 Ensure that no acid or solvent residues, especially hydrochloric acid or chlorides get into the wash cabinet.

- Remove all agar residues from petri dishes.
- Remove blood clots and residues from test tubes, etc.
- Remove all stoppers, corks, labels, sealing wax residues, etc.
- Small parts - such as stoppers, faucets and taps - should be secured in suitable basket inserts.

Note

- Petri dishes and similar glassware should be placed in the correct insert with the soiled side facing the center.
- Insert pipettes with the pointed end downwards.
- Quarter inserts should be placed in the mobile unit with at least 3 cm between them and the edge of the mobile unit.

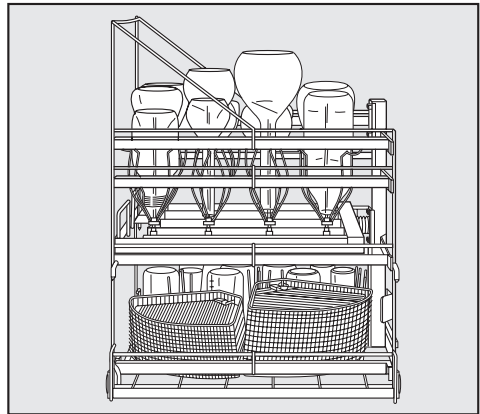

E 741 Injector mobile unit

With respective modules to clean wide necked and/or narrow necked glassware in 1 - 3 levels.

Applications

Transfer cart for loading and unloading the machine

 When a disinfection process is being carried out according to national standards, the contaminated surfaces of the cart must be disinfected with a spray in accordance with national health and safety regulations, after the machine has been loaded.

The transfer cart legs are height adjustable.

Adjust the height so that the opened door of the lab glassware washer is held under the sidewise latches of the transfer cart.

If using the transfer cart with a lab glassware washer without a base, the foot pedal position of the transfer cart needs to be changed.

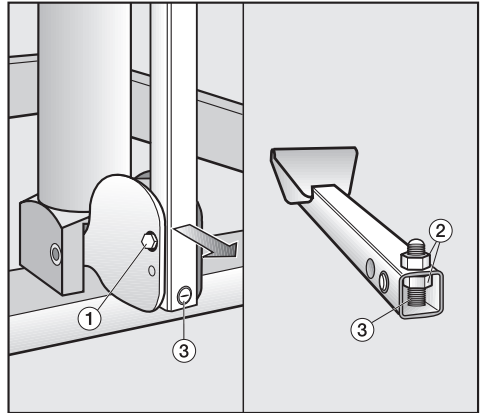

- Unscrew the foot pedal, ①.
- Loosen the counter nuts, ②, at the adjusting screw, ③.
- Screw the adjustment screw, ③, further through the foot pedal to reach the suspension point earlier.
- Tighten the counter nuts.
- Screw in the foot pedal.

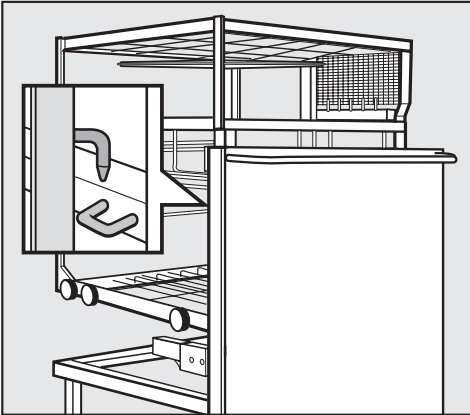

- Push the transfer cart, as far as it will go, under the open door of the lab glassware washer.
- Direct the mobile unit into the latches on the transfer cart using both hooks.
- Lock the wheels.
- To lift the mobile unit onto the door, step on the foot pedal of the transfer cart.

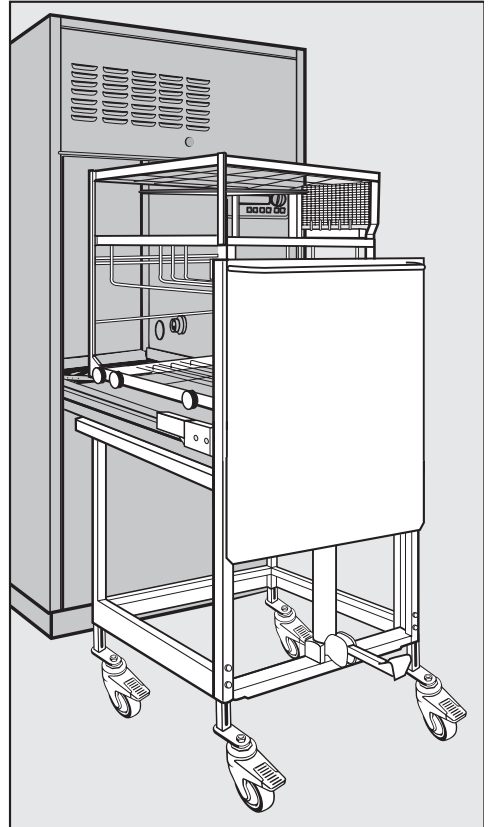

- To lower the mobile unit, step all the way down on the foot pedal.
- When the program is finished, back the transfer cart against the lab washer. The lab washer door must hook under the sideways latches.
- Pull the mobile unit onto the open door as far as it will go. It can then be lifted and transported with the transfer cart.

Adding of liquid detergents and neutralizers

 Use only cleaning agents specially designed for lab washers and regard the application recommendations of the manufacturer!

This machine is fitted with 2 dispensers as standard:

- Dispensing system DOS 1 (blue) to dispense liquid cleaning detergents. The dosing rate is 120 ml/min.
- Dispensing system DOS 3 (white) to dispense neutralizing agent (acid). The dosing rate is 20 ml/min.

Additional DOS modules (optional):

- Dispensing system DOS 2 (white). The dosing rate is 20 ml/min.
- Dispensing system DOS 4 (green). The dosing rate is 120 ml/min.

The amounts of detergent and neutralizers required, depending on the application chosen for this machine, are dispensed through these dispensing systems.

Priming the DOS dispensers

The liquids can be filled into 10 l plastic containers, which are color coded for the corresponding dispensing system.

When first commissioning, or when the message "FILL DOS 1 CONTAINER" and/or DOS 2, 3, 4 flashes in the display after switching on or at the end of a program, fill the storage container with the correct agent.

If the message "CHECK DISPENSING SYSTEM 1" and/or "DISPENSING SYSTEM 2, 3, 4" flashes in the display, (the program has been automatically put on hold), check and the storage container and the dispensing hoses and refill if necessary.

When first commissioning or when the message "CHECK DISPENSING SYSTEM..." appears start the DOS-FILL program to prime the dispensing system (see "Priming the liquid Dispensing system").

 Exercise caution when handling detergents!
Follow the instructions and relevant safety procedures carefully.
Wear protective gloves and goggles.

Adding of liquid detergents and neutralizers

Filling the containers with the relevant detergent or neutralizer

- Turn the lab washer off using the power switch.

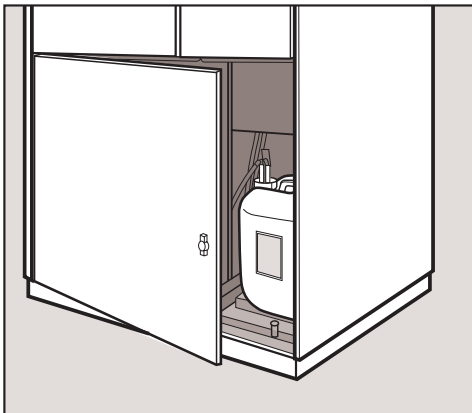

- Open the service panel on the bottom right of the machine.

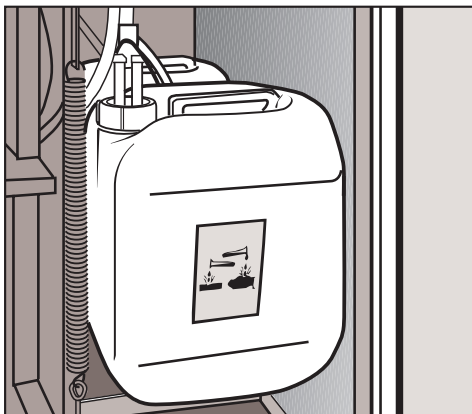

- Take the storage container out of the unit, open it and fill with the agent required. Observe the color code.

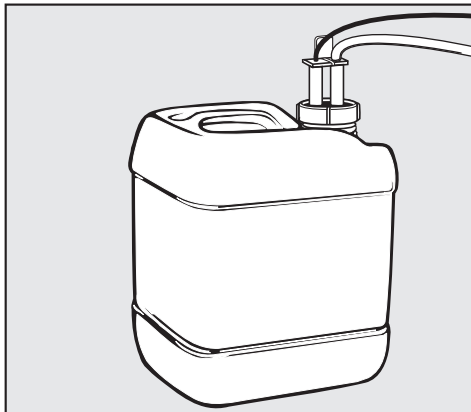

- Insert and secure the siphon tube into the container. Observe the color code.

The message clears once the storage containers have been filled.

Please remember to refill the containers in a timely manner, they should not be emptied completely.

If the container is not in use, the refill function for the dosage system not used can be shut off and the respective display message be avoided (see "Program manual - Machine function / Dispensing - Query container").

Adding of liquid detergents and neutralizers

Priming the liquid dispensing systems

Before the machine is first used, and later if one or more containers has been allowed to empty, the dispensing system(s) for liquid media must be vented.

- Press the ON/OFF **I-O** button.
- Select operating level "B".
- Select from the following as required:
Program DOS 1-FILL
Program DOS 3-FILL
(see under "Operation - B. Free program selection").
Optional:
Program DOS 2-FILL
Program DOS 4-FILL
(if DOS 2 and/or DOS 4 pumps have been built in).
- Press the "Start"  button.

The DOS-FILL Service Program are allocated by default to program places 58-61, but they can be allocated to other program places.

Dispensing system maintenance

To ensure safe function the following maintenance should be carried out by a Miele Service Technician at specified intervals.

Every 12-18 months:

Inspect the hoses in the dispensing system(s). Replace if necessary.

External Dispensing systems

If external pumps are to be used for dispensing liquid detergent, please inform the Miele Technical Service Department. The notes in the Programming Manual under "Machine functions" must be observed.

Power switch

(With the "emergency cut-off function" set to **I-ON**.)

When switching on, selecting or changing the operating level there are four operating levels available:

A = Fixed program / Programs with free access

B = Free program selection

C = AWK – Automatic mobile unit recognition (program selection via mobile unit coding)

D = Programming / free program selection / change code (see "Programming manual")

Turning on

- Open the water valves (if turned off).
- Press the ON/OFF **I-0** button.

In operating levels A, B and D the most recently selected PROGRAM NAME appears and in operating level C "AUTOMATIC MOBILE UNIT RECOGNITION" is displayed.

To change the operating level

- Press **<** and **>** at the same time. Operating levels A B C D will appear in the display.
- Select the operating level you want using the **<** or **>** keys.

■ Press **⏏** to confirm selection.

■ Enter your code when requested by the display.

The code is set by default to >0000<.

■ Press the "Start" button **⏏**.

[0000] appears.

■ Enter numbers using the **+** and **-** keys.

■ Select number position with the **<** or **>** key.

■ To confirm code press **⏏**.

If you enter it incorrectly: FALSE CODE, ENTER AGAIN will appear in the display.

■ Close the door.

Selecting or changing your own code

The factory set code can be changed (see "Programming Manual - System function").

Code 1 for levels ABC

Code 2 for levels ABCD

Operation

Starting a program

You can find detailed and important information regarding the Miele default programs in the program chart of the supplied Programming Summary.

A. Fixed program









To utilize access level "A", fixed programs must be assigned for access. See the Programming Manual section on "System Functions" for details on assigning programs. Once programs are assigned to access level "A" they can be operated in the following manner.

- Select operating level "A".
- Check in the display that the program shown is the one required. If several fixed programs have been made freely accessible, select the one required using the program selector.
- Press the "Start"  button.

B. Free program selection

- Select operating level "B".

With operating level "B" there are three possibilities for program selection.

1. Program places 1 - 23 can be selected using the Program selector.
 - Turn the program selector to the required program.
The program name appears in the display.
2. Programs above place 24 are selected using the  and  keys.
 - Turn the program selector to 24.
 - Press  (scrolls upwards) or  (scrolls down) until the required program is shown.
3. The PROGRAM SURVEY menu lists all stored programs. A program can be selected from this menu.
 - Select PROGRAM SURVEY with  and confirm with .
 - Select a program using  or .
 - Press  to confirm selection.

This exits the PROGRAM SURVEY, and the selected program is shown in the display.

After selecting one of the three options above:

 - Press the "Start"  button and the program will proceed.

For further information on program selection see "Operating Level B" in the "Programming Manual".

C. Automatic mobile unit recognition (AWK)

- Select operating level "C".
- Push the coded mobile unit into place (See, "Setting mobile unit coding").
- Close the door.

Important:

It is absolutely essential to check that the program required for this mobile unit is the one shown in the display, before starting the program by pressing the "Start" button. Otherwise inadequate cleaning could result. Please make sure, that the places assigned for programs using AWK (Automatic mobile unit recognition) are not changed at random.

- Press the "Start"  button.

Document any program and dosage changes.

Program sequence

After being started the program will proceed automatically. It is finished when PROGRAM END appears in the display and the background lighting flashes (press any button to switch off the flashing lights).

The flashing lights can be permanently switched off. See "Programming Manual - System Functions".

Detailed information on program sequences is given in the appendix of the "Programming Manual".

The display background lighting goes out automatically after approximately 15 mins. To bring it back on again press one of the touch buttons.

Turning off



- Press in and release the ON-OFF, **I-0**, button.
- Turn off the water valves.

Operation

To change or cancel a program











If the "Start" button  has already been pressed:

1. In operating levels B or D

- Press the "Stop"  button (the program is interrupted).
>CANCEL< OR >CONTINUE<
appears in the display.
- Select >CANCEL< with the  cursor button. (The cursor > < flashes.)
- Press the "Start"  button (the program is cancelled and the water is drained). DRAIN WATER appears in the display.
- After the water has been drained the required program can be selected and started.

2. In operating levels A or C

Select operating level B or D.
(Note: You will be asked for your code.)
Proceed as follows:

- Press  and  at the same time.
Operating levels A B C D will appear in the display.
- Select operating level B or D with the  or  key.
- Press  to confirm selection.
- Enter your code when requested by the display.
- Press the "Start" button .
[0000] appears.
- Enter numbers using the  and  keys.
- Select number position with the  or  key.
- To confirm code press .

If you enter it incorrectly: FALSE CODE,
ENTER AGAIN will appear in the display.

- In operating levels B or D proceed as described under **1**.

Cancelling a program

If a program needs to be interrupted or cancelled:











1. In operating levels B or D

- Press the "Stop"  button (the program is interrupted).
>CANCEL< OR >CONTINUE<
appears in the display.
- Open the door.
Important for machines with a **clean and an unclean side**:
With the setting "WITHOUT DOOR INTERLOCK" - "YES" the doors on either the clean or unclean side can be opened. If the setting "WITHOUT DOOR INTERLOCK" - "NO" is selected, only the door on the unclean side can only be opened at this stage.

 Caution! Water and items in the machine may be hot. There is a danger of burning or scalding.

- Arrange the parts securely observing any protective measures.
- Close the lift door.
- Press the "Start"  button. The program continues.

2. In operating levels A or C

- Press the **I-0** button. The program is interrupted.
- Select operating level B or D.
(Note: You will be asked for your code.)
Proceed as follows:
- Press the On-Off, **I-0**, button. The machine continues.
 - Press  and  at the same time.
Operating levels A B C D will appear in the display.
 - Select operating level B or D with the  or  key.
 - Press  to confirm selection.
 - Enter your code when requested by the display.
 - Press the "Start" button .
- [0000] appears.
- Enter numbers using the  and  keys.
 - Select number position with the  or  key.
 - To confirm code press .
- If you enter it incorrectly: FALSE CODE, ENTER AGAIN will appear in the display.
- In operating levels B or D proceed as described under **1**.

Serial interface

Each machine is supplied with a 5 m long interface cable for data transfer between the Profitronic system and an external report printer or PC.

The interface cable is rolled up inside the machine and must only be connected by a Miele Service Technician.

The serial interface is RS 232 compatible.

Various printers can be used as external printers:

- Epson-compatible sign-set
- HP Laserjet

For the interface configurations see "PC/Printer Function" in the "Programming Manual".

The address of the 9-pole pin sub-D plug of the serial interface cable:

- 5GND (ground)
- 3TXD (transmit)
- 2RXD (receive)
- 1-4-6 (linked)
- 7-8 (linked)

A standard null-modem or laplink cable can be connected.

The extension cable to the printer/PC must not exceed 32 ft. (10 m).

Please note the following when connecting a printer or PC:

- Only use an industry-standard PC or printer.
- When installing the machine take the dimensions of the printer/PC into account.

The printer settings are described in the chapter PC/Printer function in the program manual.

The report printer offers the following print options:

- Program print
- Additional functions print
- Rinse protocol print
- Fault protocol print

Cleaning the filters in the wash cabinet

 The machine must not be used without all the filters in place.

The filter combination in the base of the wash cabinet should be inspected regularly and cleaned if necessary.

Cleaning the fine filter

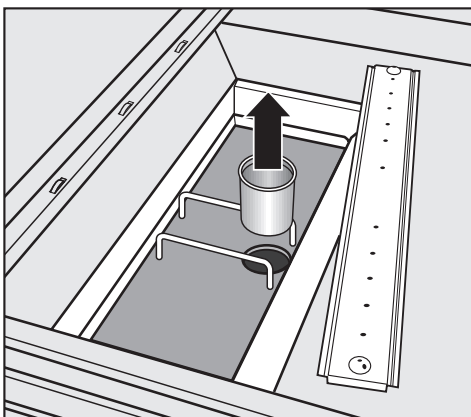

- Remove the fine filter and clean if necessary.

Cleaning the flat filter

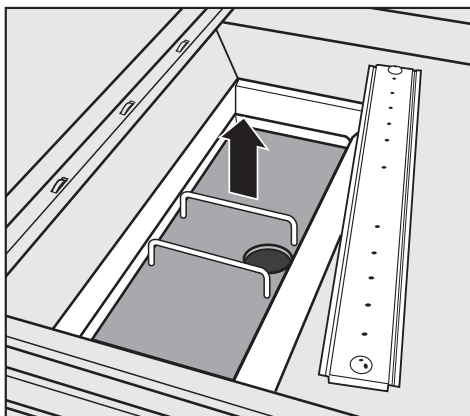

- Remove the flat filter and clean if necessary.

Cleaning the filter system for the circulation pump

Two filters are situated under the flat filter (on the right next to the heater block) for the protection of the circulation pump.

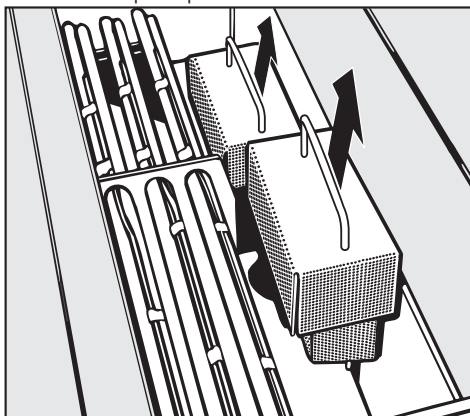

- Pull the filters up and out of the holder to remove. Clean if necessary.
- Replace the filter combination in the reverse order.

Drying unit (TA) - Cleaning and care

Changing the coarse filter

The coarse filter should be changed when the message "CHANGE TA COARSE" flashes in the display.

After the coarse filter has been changed set the filter timer to zero, as follows:

- Select CHANGE TA COARSE.
- Press the "Start"  button.

When the service program has ended, a message appears in the display.

- Confirm the instruction >CONTINUE< with .

Changing the fine filter

When the message "CHANGE TA FINE" flashes in the display the fine particle filter must be changed.

After the fine filter has been changed set the filter timer to zero, as follows:

- Select CHANGE TA FINE.
- Press the "Start"  button.

When the service program has ended, a message appears in the display.

- Confirm the instruction >CONTINUE< with .

Only use **Miele S-class particle filters** to ensure a faultless operation of the machine.

The service programs CHANGE TA - COARSE and FINE were set by default to program places 62 and 63, but they can be moved to other program places. See "System functions" in the Programming Manual.

Maintenance of report printer (Option)

Replacing the print paper

Replace the print paper (58 mm wide) when the red indicator lights up in the report printer.

- Open and pull down the front panel of the printer.
- Take the empty roll together with its spindle from the roll holder, fit the new roll on the spindle and put back in place.
- Cut the paper at an angle and guide it up over the paper transport roller (slit behind the ribbon cartridge). Press the green paper transport button until the paper reemerges above the ribbon cartridge (see the illustration on the inside of the front panel).
- Guide the paper through the slit of the front panel. Shut the front panel.

Replacement paper rolls (58 mm wide, outer diameter approx. 50 mm) can be obtained from the Miele.

Replacing the ribbon cartridge

- Open and pull down the printer front panel.
- Pull the ribbon cartridge (above the paper roll) forward and out of its holder and replace it with a new one. The paper must be guided between the ribbon and the cartridge housing.
- Turn the small wheel for manual ribbon transport on the right clockwise until the ribbon is tight.
- Cut the paper at an angle and guide it through the slit of the front panel. Shut the front panel.



 Please refer to the installation diagram supplied with the machine.

Replacement ribbon cartridges can be obtained from the Miele.

Installation

Steam/Electro or Electro/Steam conversion

If the machine is convertible, the heating type can be changed in the service program from STEAM>ELECTRO or ELECTRO>STEAM.

- Select program STEAM>ELECTRO or ELECTRO>STEAM (see "Operation / B. Free program selection").
- Press the "Start"  button.
When the service program has ended, a message appears in the display.
- Confirm the instruction >CONTINUE< with .

 Mount on non-combustible floor only!

 All electrical work must be carried out by a suitably qualified electrician in accordance with local and national safety regulations.

**WARNING:
THIS APPLIANCE MUST BE
GROUNDED**

- Installation, repairs and other work by unqualified persons could be dangerous. The manufacturer can not be held responsible for unauthorized work.
- The direction the motor spins depends of the electrical connection of the machine. Connect the machine in-phase for clockwise rotation.

The machine must only be operated with the voltage, frequency and fusing shown on the data plate.

The data plate is on the cover plate behind the service panel of the unclean side.

The wiring diagram is secured to the inner side of the service panel.

The unit is convertible for steam or electric heating. Hook-up requirements are as follows: 208 V, 60 Hz, 3 phase, 30 Amps and rated load 10 KW.

Plumbing

Water connection

This machine must be connected to the water supply in accordance with all national and local plumbing codes.

Faucets and drain connections should be situated as close to the machine as possible, and be easily accessible.

All water supply pressures should be between 30 and 145 psi. The machine is supplied with 3 connection hoses 11.5 ft. (3.5 m) long with $\frac{3}{4}$ " (19 mm) female hose thread ends. If shorter hoses are needed 5 ft. (1.5 m) hoses are supplied with the machine.

Do not shorten hoses!

The machine cannot be operated with an inflow pressure of less than 10 psi flow pressure.

Requirements (refer to the Installation Diagram for more information)

1. Cold water connection:

One $\frac{1}{2}$ " (13 mm) cold water supply line with a standard $\frac{3}{4}$ " (19 mm) male hose thread faucet is needed. The cold water supply hose is marked with blue tape.

2. Hot water connection:

One $\frac{1}{2}$ " (19 mm) hot water supply line with a standard $\frac{3}{4}$ " male hose thread faucet is needed. The water temperature must not exceed 150 °F / 65 °C (recommended: 140 °F / 60 °C). The hot water supply hose is marked with red tape.

3. DI water connection

One $\frac{1}{2}$ " (13 mm) deionized water supply line with a standard $\frac{3}{4}$ " (19 mm) male hose thread faucet is needed. The machine cannot be operated conventionally with a pressure of less than 10 psi flow pressure. In this case the installation of an optional DI pump is required. The DI water supply hose is marked with green tape.

Drainage

Connection to the drainage system and disposal of waste water must comply with local and national regulations.

- The machine comes standard with 3 drain hoses. Two have a $\frac{7}{8}$ " (22 mm) outer diameter and one has a $\frac{3}{8}$ " (9.5 mm) outer diameter, all are 5 ft. (152 cm) long. An additional, $\frac{1}{2}$ " (13 mm) internal diameter, drain hose is supplied if equipped with the optional steam condenser.
- A 2 $\frac{1}{2}$ " (64 mm) diameter standpipe or floor drain is required.
- The drainage system is fitted with a non-return valve which prevents dirty water from flowing back into the machine via the drain hose.
- The machine should preferably be connected to a separate drainage system onsite. If **separate** drainage is not available, contact your Miele application specialist for advice.
- A longer drain hose, up to 12 feet (4 m) long, is available to order from Miele.
- The drainage system must not exceed 12 feet (4 m).

Technical Data

Height:	78 ³ / ₄ " (200 cm) (minimum room height)
Width:	35 ⁷ / ₁₆ " (90 cm)
Depth:	29 ¹ / ₂ " (75 cm)
Weight (net):	approx. 1,110 lbs (505 kg)
Operating weight	approx. 1,470 (665 kg)
Voltage:	208 V 60 HZ 3 phase 30 amp
Rated load:	10 KW
Air pressure connection:	85 - 175 psi (required for steam operation)
Air pressure consumption:	3 cfm
Steam connection	36 - 145 psi
Water pressure (flow rate):	30 - 145 psi
Cold, hot and distilled water (DI):	up to max. 140 °F (60 °C)
Noise level in dB (A):	for the cleaning cycle: <70 for the drying cycle: <70
CE-mark:	MPG-Guidelines 93/42/EWG, Class IIa
Drainage length:	12 ft. (4 m)
Delivery head:	6 ft. (2 m)

Should you have any difficulties please contact the Miele Technical Service Department.

See back cover for addresses.

- Please quote the model and serial number of your machine.

This information can be found on the data plate (see also "Electrical connection").

Caring for the environment

Disposal of the packing materials

The cardboard box and packing materials protect the appliance during shipping. They have been designed to be biodegradable and recyclable.

Ensure that any plastic wrappings, bags etc. are disposed of safely and kept out of the reach of children.

Danger of suffocation! Please recycle.

Disposal of an old appliance

Old appliances may contain materials that can be recycled. Please contact your local authorities about recycling in your area.

Ensure that the appliance presents no danger to children while being stored for disposal. See "Important Safety Instructions".

When contacting the Technical Service,
please quote the model and serial number
of your appliance.

Miele
PROFESSIONAL

Miele, Inc. (USA)

National Headquarters

9 Independence Way
Princeton, NJ 08540
Phone: 800-991-9380
609-419-9898
Fax: 609-419-4298
www.mieleusa.com

Technical Service & Support

Nationwide

Phone: 800-991-9380
Fax: 888-586-8056

Miele Limited (CDN)

National Headquarters

55G East Beaver Creek Road
Richmond Hill, ON L4B 1E5
Phone: 800-643-5381
905-707-1171
Fax: 905-707-0177
www.miele.ca
professional@miele.ca